



# PO3B10A

## High Bandwidth Potato Chip

FEATURES:	DESCRIPTION:
<ul style="list-style-type: none"> <li>• Patented technology</li> <li>• High signal -3db passing bandwidth at 3.5Gbps or 1.75GHz</li> <li>• Near-Zero propagation delay</li> <li>• VCC = 1.65V to 3.6V</li> <li>• Ultra-Low Quiescent Power: 0.1µA typical</li> <li>• Ideally suited for low power applications</li> <li>• Industrial operating temperature: -40°C to +85°C</li> <li>• Available in 12pin DFN package</li> </ul>	<p>Potato Semiconductor’s PO3B10A is designed for world top performance using submicron CMOS technology to achieve GHz high bandwidth.</p> <p>The PO3B10A is a 2-channel, 2:1 Multiplexer / Demultiplexer with 3-state outputs. The switch introduces no additional ground bounce noise or propagation delay.</p>

### Pin Configuration

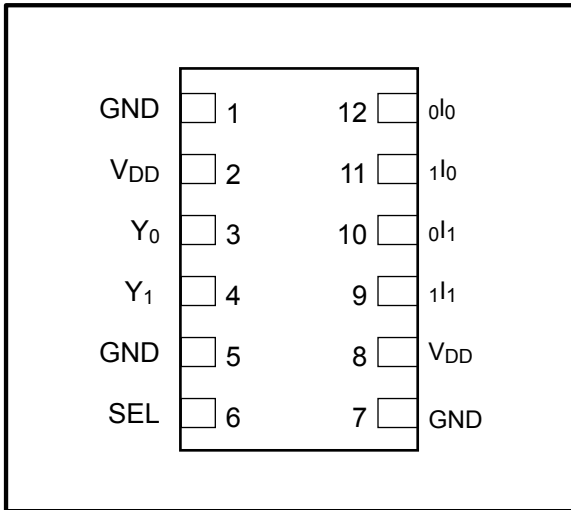

### Block Diagram

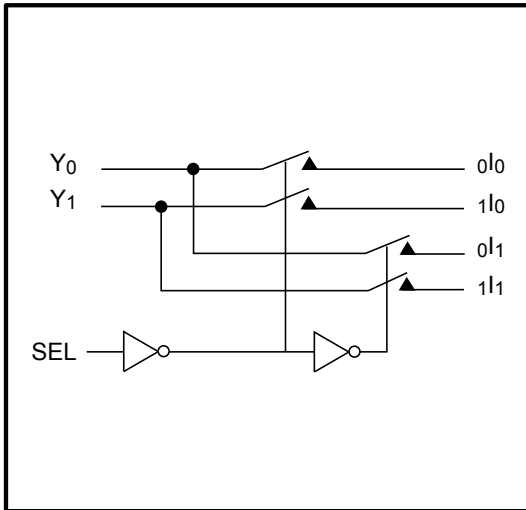

### Truth Table

Function	SEL
Y <sub>n</sub> to <sub>n</sub> I <sub>0</sub>	L
Y <sub>n</sub> to <sub>n</sub> I <sub>1</sub>	H

**High Bandwidth Potato Chip****Maximum Ratings**

(Above which the useful life may be impaired. For user guidelines, not tested.)

Storage Temperature .....	-65°C to +150°C
Ambient Temperature with Power Applied .....	-40°C to +85°C
Supply Voltage to Ground Potential .....	-0.5V to +4.6V
DC Input Voltage .....	-0.5V to +V <sub>CC</sub>
DC Output Current.....	120mA
Power Dissipation.....	0.5W

**Note:**

Stresses greater than those listed under MAXIMUM RATINGS may cause permanent damage to the device. This is a stress rating only and functional operation of the device at these or any other conditions above those indicated in the operational sections of this specification is not implied. Exposure to absolute maximum rating conditions for extended periods may affect reliability.

**DC Electrical Characteristics, 3.3V Supply**(Over the Operating Range, T<sub>A</sub> = -40°C to +85°C, V<sub>CC</sub> = 3.3V ±10%)

Parameters	Description	Test Conditions	Min.	Typ.	Max.	Units
V <sub>IH</sub>	Input HIGH Voltage	Guaranteed Logic HIGH Level	2.0			V
V <sub>IL</sub>	Input LOW Voltage	Guaranteed Logic LOW Level			0.8	
I <sub>IH</sub>	Input HIGH Current	V <sub>CC</sub> = Max., V <sub>IN</sub> = V <sub>CC</sub>			±1	μA
I <sub>IL</sub>	Input LOW Current	V <sub>CC</sub> = Max., V <sub>IN</sub> = GND			±1	
I <sub>OZH</sub>	High Impedance Output Current	0 ≤ Y, I <sub>n</sub> ≤ V <sub>CC</sub>			±1	
R <sub>ON</sub>	Switch On-Resistance	V <sub>CC</sub> = Min., V <sub>IN</sub> = 0.0V, I <sub>ON</sub> = -48 mA or -64mA		14	18	Ω
		V <sub>CC</sub> = Min., V <sub>IN</sub> = V <sub>CC</sub> , I <sub>ON</sub> = -15 mA		16	20	

**DC Electrical Characteristics, 2.5V Supply**(Over Operating Range, T<sub>A</sub> = -40°C to +85°C, V<sub>CC</sub> = 2.5V ± 10%)

Parameters	Description	Test Conditions	Min.	Typ.	Max.	Units
V <sub>IH</sub>	Input HIGH Voltage	Guaranteed Logic HIGH Level	1.8		V <sub>CC</sub> + 0.3	V
V <sub>IL</sub>	Input LOW Voltage	Guaranteed Logic LOW Level	-0.3		0.8	
I <sub>IH</sub>	Input HIGH Current	V <sub>CC</sub> = Max., V <sub>IN</sub> = V <sub>CC</sub>			±1	μA
I <sub>IL</sub>	Input LOW Current	V <sub>CC</sub> = Max., V <sub>IN</sub> = GND			±1	
I <sub>OZH</sub>	High Impedance Current	0 ≤ Y, I <sub>n</sub> ≤ V <sub>CC</sub>			±1	
R <sub>ON</sub>	Switch On Resistance	V <sub>CC</sub> = Min., V <sub>IN</sub> = 0.0V, I <sub>ON</sub> = -48mA		18	22	Ω
		V <sub>CC</sub> = Min., V <sub>IN</sub> = V <sub>CC</sub> , I <sub>ON</sub> = -15mA		18	22	

**High Bandwidth Potato Chip****Power Supply Characteristics**

Symbol	Description	Test Conditions (1)	Min	Typ	Max	Unit
<b>I<sub>cc</sub></b>	Quiescent Power Supply Current	V <sub>cc</sub> =Max, V <sub>in</sub> =V <sub>cc</sub> or GND	-	<b>0.1</b>	<b>3</b>	<b>uA</b>

**Notes:**

1. For conditions shown as Max. or Min., use appropriate value specified under Electrical Characteristics for the applicable device type.
2. Typical values are at V<sub>cc</sub> = 3.3V, 25°C ambient.
3. This parameter is guaranteed but not tested.
4. Not more than one output should be shorted at one time. Duration of the test should not exceed one second.
5. VoH = V<sub>cc</sub> - 0.6V at rated current

**Capacitance** (T<sub>A</sub> = 25°C f = 1 MHz)

Parameters	Description	Test Conditions	Typ.	Units
C <sub>IN</sub>	Input Capacitance	V <sub>IN</sub> = 0V	3.0	pF
C <sub>OFF</sub>	Port I Capacitance, Switch OFF		5.0	
C <sub>ON</sub>	Switch Capacitance, Switch ON		10.0	

**Dynamic Electrical Characteristics Over the Operating Range**(T<sub>A</sub> = -40° to +85°, V<sub>CC</sub> = 3.3V ± 10%)

Parameter	Description	Test Condition	Typ.	Units
X <sub>TALK</sub>	Crosstalk	R <sub>L</sub> = 100Ω	-60	dB
O <sub>IRR</sub>	Off-Isolation	R <sub>L</sub> = 100Ω	-60	
BW	-3dB Bandwidth	R <sub>L</sub> = 100Ω	1.75	GHz

**Switching Characteristics over 3.3V Operating Range**

Parameters	Description	Conditions	Max.	Units
t <sub>PLH</sub> t <sub>PHL</sub>	Propogation Delay	See Test Diagram	0.3	ns
t <sub>PZH</sub> t <sub>PZL</sub>	Bus Enable Time	See Test Diagram	2.0	
t <sub>PHZ</sub> t <sub>PLZ</sub>	Bus Disable Time		3.0	



# PO3B10A

## High Bandwidth Potato Chip

### Switching Characteristics over 2.5V Operating Range

Parameters	Description	Conditions	Max.	Units
$t_{PLH}$ $t_{PHL}$	Propagation Delay	See Test Diagram	0.3	ns
$t_{PZH}$ $t_{PZL}$	Bus Enable Time	See Test Diagram	2.0	
$t_{PHZ}$ $t_{PLZ}$	Bus Disable Time		3.0	

### Test Circuit for Electrical Characteristics

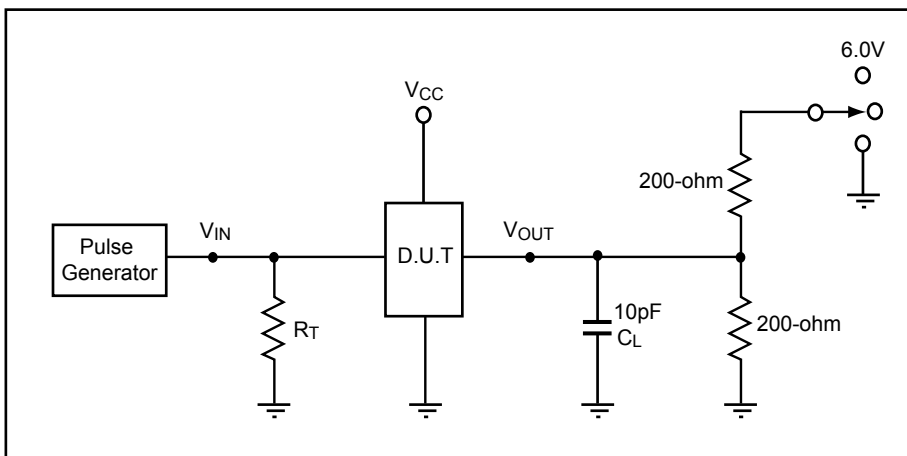

### Switch Positions

Test	Switch
$t_{PLZ}$ , $t_{PZL}$	6.0V
$t_{PHZ}$ , $t_{PZH}$	GND
Prop Delay	Open

### Switching Waveforms

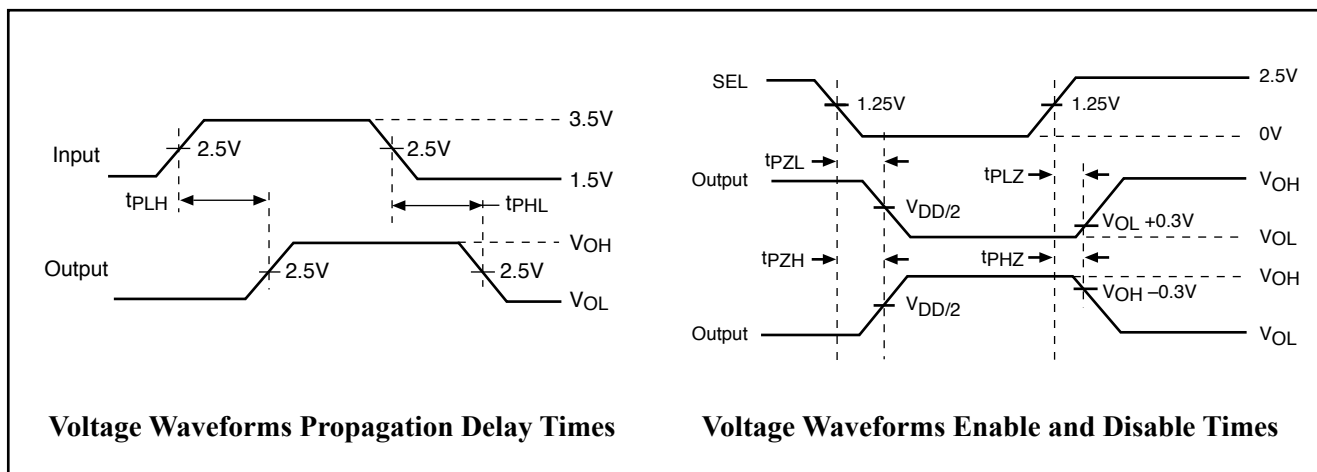



# PO3B10A

2-Channel, 2:1 Mux/DeMux Switch w/ Single Enable

## High Bandwidth Potato Chip

### Packaging Mechanical Drawing: 12 pin DFN

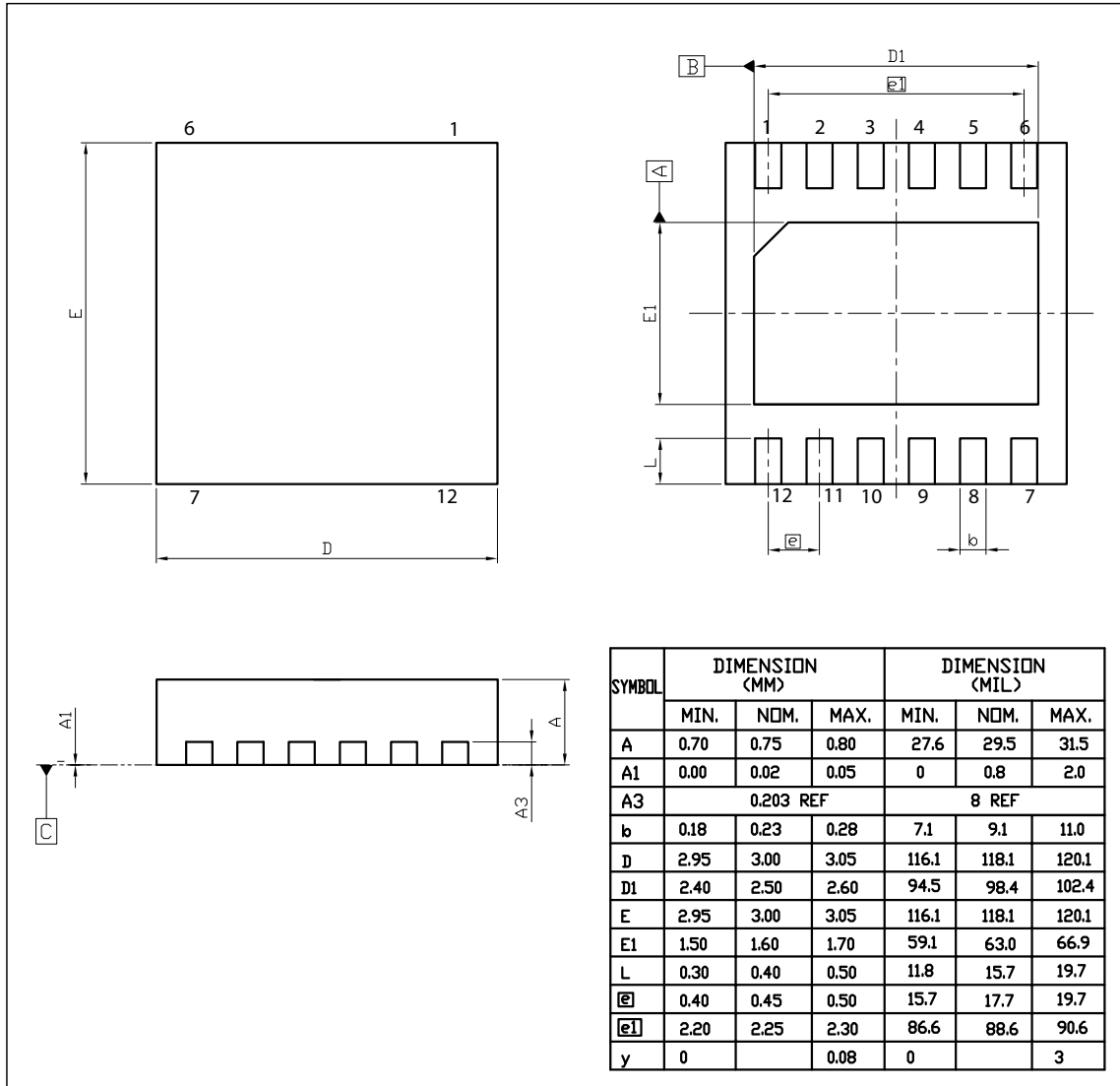

### IC Ordering Information

Ordering Code	Package	Top-Marking	T <sub>A</sub>
PO3B10ADR for Tape & Reel	12-pin DFN Pb-free & Green	PO3B10AD	-40°C to 85°C

### IC Package Information

PACKAGE CODE	PACKAGE TYPE	TAPE WIDTH (mm)	TAPE PITCH (mm)	PIN 1 LOCATION	TAPE TRAILER LENGTH	QTY PER REEL	TAPE LEADER LENGTH	QTY PER TUBE
D	12-pin DFN	12	8	Top Left Corner	26 (12")	3000	64 (20")	N/A